

Installation guide



01 Position your gates

Measure up the dock area and mark out the desired gate location ensuring the gate is parallel to the dock edge.

Check the available height over the main gate post to ensure clearance for when the gate is in the open position. (The open gate dimension can be checked by measuring your gate in the freighted position on the pallet.)

Unpack your gate and stand it in its location in the closed position to ensure you are happy with the location, including the receiver post.

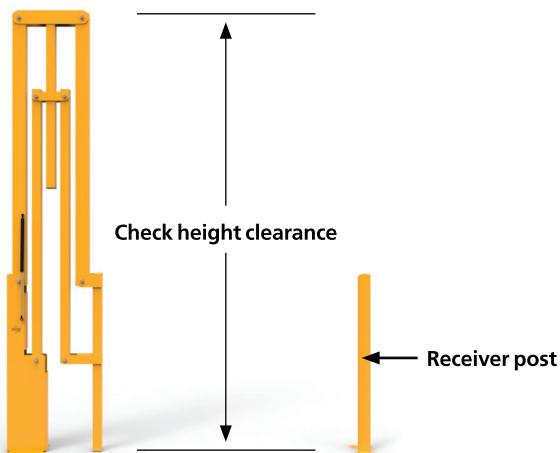

02 Fixing down

Mark out the bolt hole positions.

Assuming the dock floor is concrete, drill (x 6) 12mm diameter holes x 80mm deep at each hold-down bolt location.



Place the gate in position and fasten down with the m12 x 80 masonry through bolts provided. Make sure the main gate post is fixed down perfectly plumb for the best results. You may need to apply packers under the post to achieve this result. Repeat the process for the receiver post.

03 Fitting Gas Struts

Fit the gas struts to the gate post ensuring that the stainless-steel rams are in the facing down position. (See image below). This is very important, as placing the gas strut upside down, will dramatically reduce the life of the strut.

Open the gate then attach the gas strut to the top rail.



04 Fitting the handle

Fit the handle to bottom rail on the accessible side of the gate, positioned between 1000mm – 1200mm from the bolt in the main post (see image below).

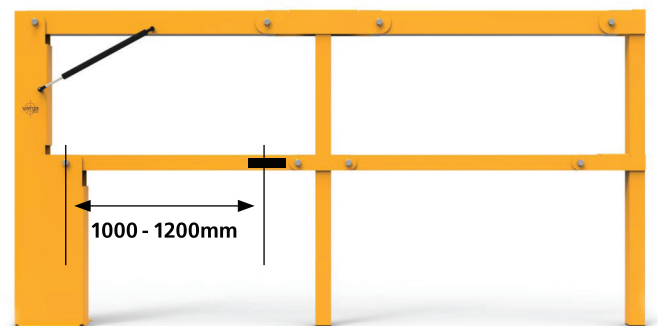

Dock-PRO Single Gate



05 Fine adjustments

Action the gate a few times to bed in the pivot connections and gas struts. If the gate remains a little stiff to use, back off the tension of the bolts at the pivot points. After the gate has been in use multiple times, you may need to adjust this tension to achieve a comfortable operating force.

06 Maintenance

Ensure the powder coated surfaces are kept free from dirt / dust build up to eliminate moisture retention.

Periodical tensioning of the pivot bolts will be required to maintain ease of use action.

The hold down bolts should also be checked at 6 monthly intervals as they may lose tension over time.

