

# 165mm Steel In-ground Bollard.



## Suggested Uses.

- Heavy duty property and asset protection.
- Protecting doorways from forklift impacts
- Retail store-front protection from rogue vehicle impacts

## Benefits.

- Made in New Zealand with 10 Year Warranty
- UV Stabilised Powdercoat
- Black domed cap can be removed to allow the bollard to be filled with concrete.

## Specifications.

Code	49-IG165
Description	165mm Steel Inground Bollard
Material	Hot Dipped Galvanised Steel
Height	1630mm (1100mm above ground)
Diameter	165mm
Weight	33kg
Wall Thickness	4.5mm

## Codes.

49-IG165G	Inground Bollard - Plain Galvanised
49-IG165GY	Inground Bollard - Galvanised with Yellow Powdercoat

## Installation.

Cut or core drill minimum 350mm diameter and 550mm deep hole, place bollard in hole, fill with concrete 20mpa or higher.

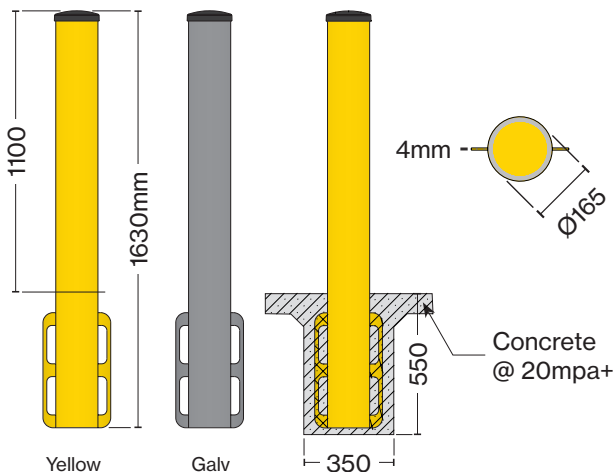

Scan here to view the webpage.

