

TRU-GARD Anti-Climb Barrier System

A

B

C

D

A

B

C

D

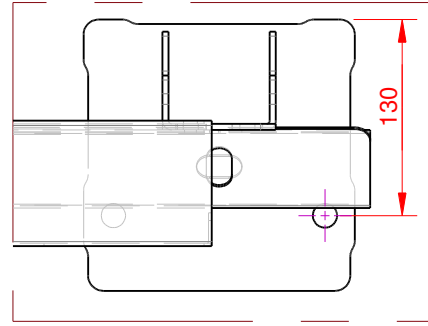
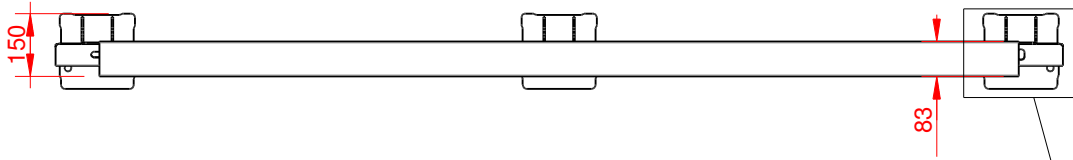
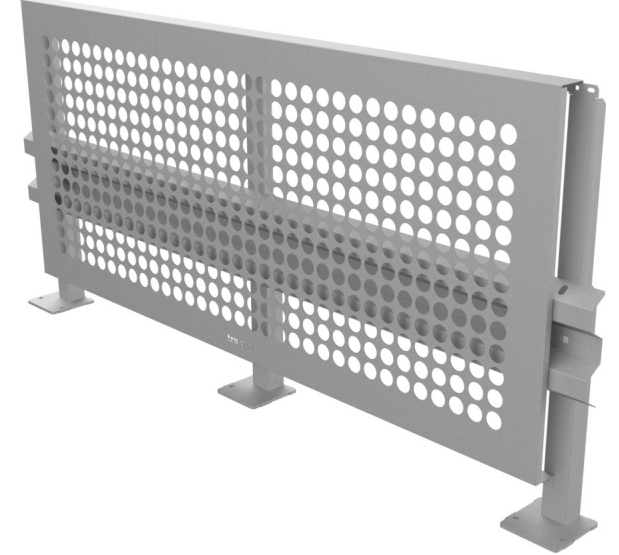
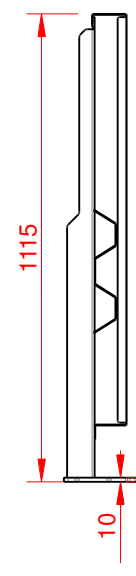
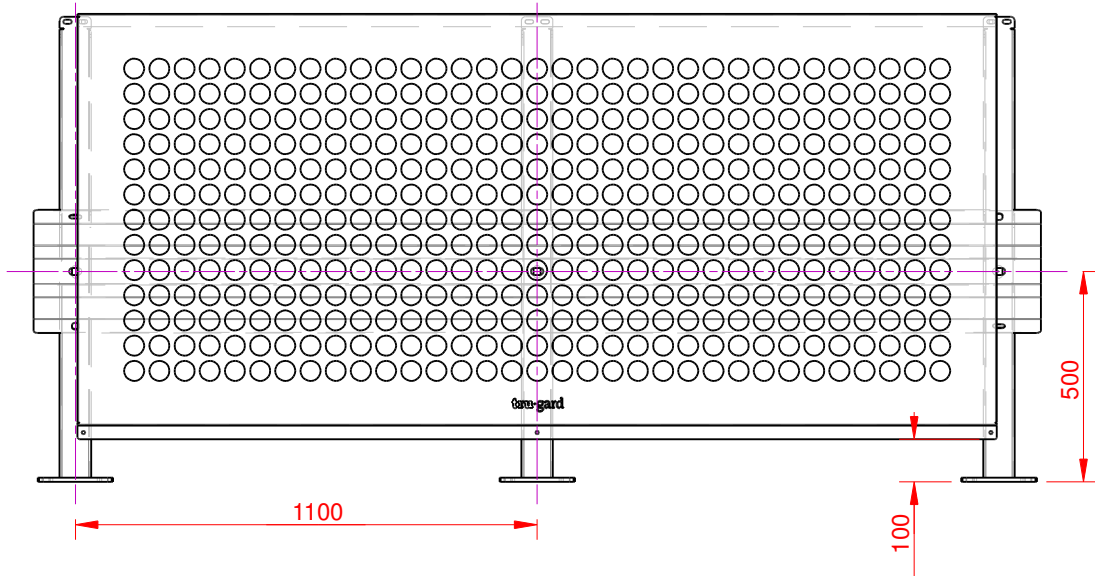

Detail A



Specifications:

- Compliant to AS/NZS1170.1:2002 Section 3.8
- Compliant to AntiClimb building codes
- Complete system of components inc. corners/caps
- 48mm holes in Anti-Climb screen
- 2x M12 x 100 Screwbolt fixings per post
- Fixings 130mm from edge of plate/floor (Detail A)
- Hot Dip Galvanised finish

Drawn by Tristan Stanners	Checked by Mark Taylor	Date 20-10-2021	Scale NTS - A4 L
THIS DRAWING IS INTELLECTUAL PROPERTY OF: TRU-BILT [®] INDUSTRIES 20 Townleys Rd, Dunedin, New Zealand <small>All product designs are subject to copyright and cannot be copied in whole or part.</small>			
TRU-GARD Anti-Climb Barrier System		Edition 1.0	Sheet -
TRU-GARD			